

CLARKE®

weld



WELDING HEADSHIELD

MODEL NO: HS1

PART NO: 6000700

OPERATION & MAINTENANCE INSTRUCTIONS

CE

ORIGINAL INSTRUCTIONS

GC1120 - REV 1

INTRODUCTION

Thank you for purchasing this CLARKE Welding Headshield.

Please read this manual thoroughly and follow the instructions given. In doing so you will ensure the safety of yourself and that of others around you, and you can look forward to the product giving you long and satisfactory service.

GUARANTEE

This product is guaranteed against faulty manufacture for a period of 12 months from the date of purchase. Please keep your receipt which will be required as proof of purchase.

This guarantee is invalid if the product is found to have been abused or tampered with in any way, or not used for its intended purpose. Faulty goods should be returned to their place of purchase, no product can be returned to us without prior permission.

This guarantee does not effect your statutory rights.

ENVIRONMENTAL PROTECTION

If broken, do not dispose of this product with general household waste. This product contains valuable raw materials and should be disposed of appropriately at a recognised disposal facility.

SPECIFICATION

Viewing field (W x H)	103 X 81 mm
Filter shade number	(DIN) 11
Operating temperature range	-5°C to +50°C
Weight	0.44 kg
Dimensions (D x W x H)	300 x 215 x 230 mm (excluding headband)

GENERAL SAFETY WARNINGS

- The protective lens in this headshield is breakable and should only be used for welding applications.
- This headshield is designed for use in arc welding or cutting applications such as ARC, MIG/MAG.
- Use this headshield for face and eye protection against harmful rays, sparks and spatter from welding and cutting.
- This headshield is not suitable for laser welding, laser cutting or "overhead" welding applications, or for oxyacetylene.
- Never place this product on a hot surface.
- Do not make any modifications to this product. Protection can be seriously impaired if modifications are made.
- When necessary, use identical replacement parts. This will ensure that the safety of the product is maintained.
- Only trained welders should use this product.
- Do not use without protective lens cover installed. Do not use if any part of the headshield is cracked or broken.
- Do not use this headshield for welding above the range of DIN 11. Harm to the eyes and impaired eyesight may result.
- Always use the mask for the duration of exposure to hazards. Stop work if dizziness or eye irritation occurs or if the mask becomes damaged.
- Please keep these instructions in a safe place for future reference.

PREPARATION & USE

ADJUSTING THE HEADBAND TO FIT

The headband should be adjusted both in diameter and height to fit the wearer's head. To do this:

1. Press the headband adjustment knob on the back of the headband and rotate the knob either left or right to expand or contract the headband.
2. The top headband can be adjusted by bending the strap and positioning the peg in the appropriate hole.

ADJUSTING THE TILT ANGLE

1. Loosen the adjusting nuts slightly.
2. Move the tab onto the chosen pin on the headband, repeat on both sides.

NOTE: The tabs should be located on the same pin on either side of the headband.

3. Retighten the adjusting nuts.
4. Try the headshield on and if necessary, readjust.

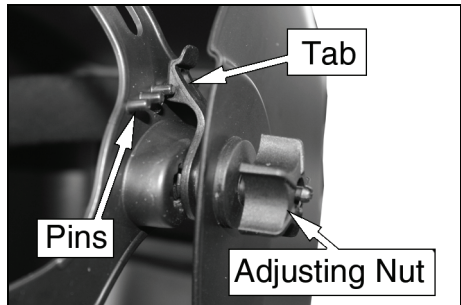

CARE & MAINTENANCE

GENERAL

Damaged components must be replaced immediately to avoid risk of eye and face injuries. Periodically inspect the lenses. Cracked, pitted or scratched lenses reduce vision and seriously reduce level of protection and should be replaced with genuine, certified spare parts. The lens can be removed for cleaning or replacement after prising out the lens retainer.

CLEANING & STORAGE

The headshield should be stored in its box or similar place.

Clean all lenses with a soft tissue and suitable lens cleaning fluid. Do not use solvents. Never use tools or other sharp objects to remove material from the lens or headshield. This may cause damage which may impair function and invalidate the warranty.

COMPONENT PARTS

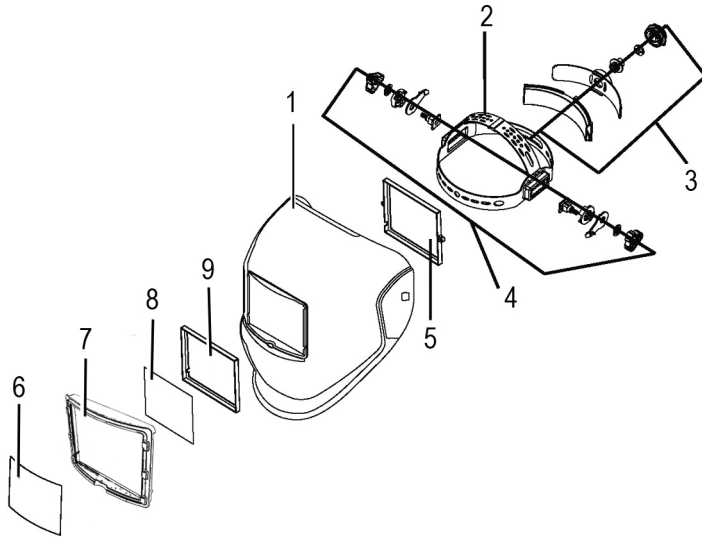

1	Helmet Body
2	Headband
3	Headband Adjustment Knob
4.	Headband Angle Adjustment Knobs
5	Rear Lens Holder
6	Clear Lens Protector
7	Lens Frame
8	Dark Lens
9	Lens Spacer

DECLARATION OF CONFORMITY



Clarke[®]
INTERNATIONAL

Hemnal Street, Epping, Essex CM16 4LG

DECLARATION OF CONFORMITY

This is an important document and should be retained.

Product Description: Welding Head Shield
Model number(s): HS1
Serial / batch Number: N/A
Date of Issue: 12/11/2020
Certificate Number: C5116GX/R2, C4844GX/R2
Notified Body: NB 0196
DIN CERTCO GESELLSCHAFT FÜR KONFORMITÄTBEWERTUNG MBH
Alboinstraße 56
12103 BERLIN
Germany

We hereby declare that this product(s) complies with the following directive(s):

(EU) 2016/425 Personal Protective Equipment Regulation.

The following standards have been applied to the product(s):

DIN EN 175:1997-08, DIN EN 166:2002-04, DIN EN 169.

The technical documentation required to demonstrate that the product(s) meet(s) the requirement(s) of the aforementioned directive(s) has been compiled and is available for inspection by the relevant enforcement authorities.

The CE mark was first applied in: 2013

Signed:

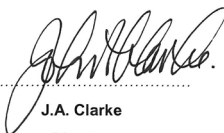

J.A. Clarke
Director

NOTES

A SELECTION FROM THE VAST RANGE OF

Clarke®

QUALITY PRODUCTS



AIR COMPRESSORS

From DIY to industrial, Plus air tools, spray guns and accessories.

GENERATORS

Prime duty or emergency standby for business, home and leisure.

POWER WASHERS

Hot and cold, electric and engine driven - we have what you need

WELDERS

Mig, Arc, Tig and Spot. From DIY to auto/industrial.

METALWORKING

Drills, grinders and saws for DIY and professional use.

WOODWORKING

Saws, sanders, lathes, mortisers and dust extraction.

HYDRAULICS

Cranes, body repair kits, transmission jacks for all types of workshop use.

WATER PUMPS

Submersible, electric and engine driven for DIY, agriculture and industry.

POWER TOOLS

Angle grinders, cordless drill sets, saws and sanders.

STARTERS/CHARGERS

All sizes for car and commercial use.

PARTS & SERVICE:

0208 988 7400

Parts Enquiries

Parts@clarkeinternational.com

Servicing & Technical Enquiries

Service@clarkeinternational.com

SALES: UK 01992 565333 or Export 00 44 (0)1992 565335

Clarke INTERNATIONAL Hemnall Street, Epping, Essex CM16 4LG
www.clarkeinternational.com